



GIUSEPPE AREZZI
IS AN ITALIAN INTERIOR AND
FURNITURE DESIGNER GRADUATED
FROM THE POLITECNICO DI MILANO
AND BASED IN RAGUSA IN SICILY.
HIS PRACTICE - BOTH CONCEPTUAL
AND COMMERCIAL - COLLABORATES
WITH INTERNATIONAL INSTITUTIONS,
GALLERIES, BRANDS AND
PRIVATE CLIENTS.

Giuseppe's research - linked to his experience and his home territory - gives life to contemporary products and spaces by tending his vision to transformability and multifunctionality.

He is interested in no longer used functional archetypes, both by reinterpreting them in a contemporary way, or by designing ready-made of new objects and spaces. Giuseppe's design code - always different according each time to diverse needs - has at the same time both a local and a global language.

Giuseppe Arezzi's work has been exhibited and published internationally: in 2019 he was nominated through the finalists in the "Pure Talents Design Contest" at the "Imm Cologne" furniture fair, in 2021 he joined the "Design and Decorative Arts" permanent collection of the "CNAP - Centre National des Arts Plastiques" in Paris, in 2022 he joined the permanent collection of the "Vitra Design Museum" and he has been nominated "Young Talent of The Year" by the magazine "Elle Decor Italia" at the "EDIDA - Elle Deco International Design Awards".

Giuseppe Arezzi is lecturer at IED and ABADIR.

SELECTED PROJECTS



MANIC# ARMCHAIR
SELF PRODUCTION
2012

More than just a land of contrasts, Sicily is a land of history. History not only about peoples and kings, but also about large families of the earth formed, hearts ordered.

A tradition, ours, which looks at the best form of all: the essential. The armchair Manic# comes entirely from our land, have not been foreign hands to draw it and build it. Hoes, brooms, rolling pins. Wood not only of our land, but also of our homes.

The same tools that our ancestors have used today give a new life to a product of a land that looks to the past as it flies towards the future, firmly in the traditions and unbeaten in inventiveness.

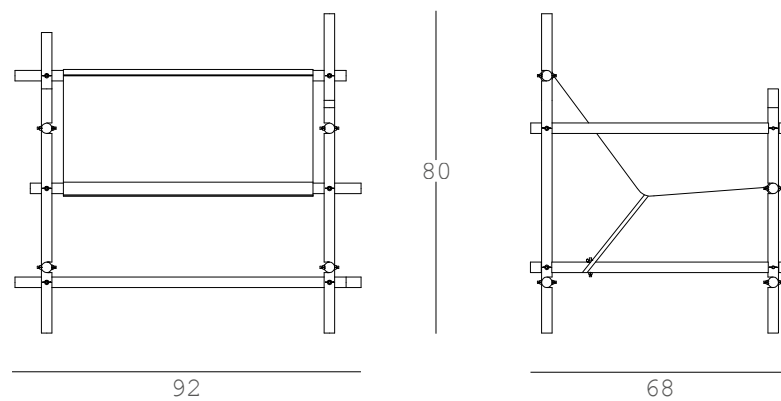



MANIC# armchair is a "self-produced" project, it is completely demontable and it is made in beech solid wood brooms, glossy canvas and leather straps. MANIC# has been selected and exhibited at the Lake Como Design Fair's first edition in September 2018. Manic# is part of the permanent collection of the "Vitra Design Museum".

BEATA SOLITUDO
INSTALLATION
CANTIERE GALLI DESIGN
CURATED BY DOMITILLA DARDI
ROME
2017

Beata Solitudo is the shelter of the contemporary hermit - technological, dynamic and primitive - a small house with everything you need to live on your own: a place where to cook, a place where to eat, a place where to bathe, a place where to sleep and an attic for storing food and looking at the stars; there are also spaces to breed animals and all the tools one might need to exploit renewable energy sources.

This shelter has been designed as a product rather than as definitive architecture; with his rigid, self-supporting structure it can be placed anywhere in the world. The wooden walls, conceived as frames, allow to weave a different coverage every time, depending on where the refuge is assembled: it can turn into a house made of carpets if settled down in Mongolia or in the desert, of palm trees in Thailand or in equatorial countries, of sealskin in Antarctica ...

Beata Solitudo is not just a physical space, it also aims to represent the lifestyle of the technological dynamic and primitive hermit.

This installation is part of the project "Una Stanza Tutta Per Sé", curated by Domitilla Dardi at Cantiere Galli Design in Rome.

The room: The two self-supporting walls are made of solid walnut wood and linen fabric.

The floor is a woven coconut fiber carpet.

The table at the center of the room - also made of solid American walnut wood - is designed exclusively for this exhibition.

The maquette - 1:20 scale - made of American walnut wood and linen fabric, is made all by hand.

The room's walls are blue.

The ceiling is covered with a blue cotton fabric.

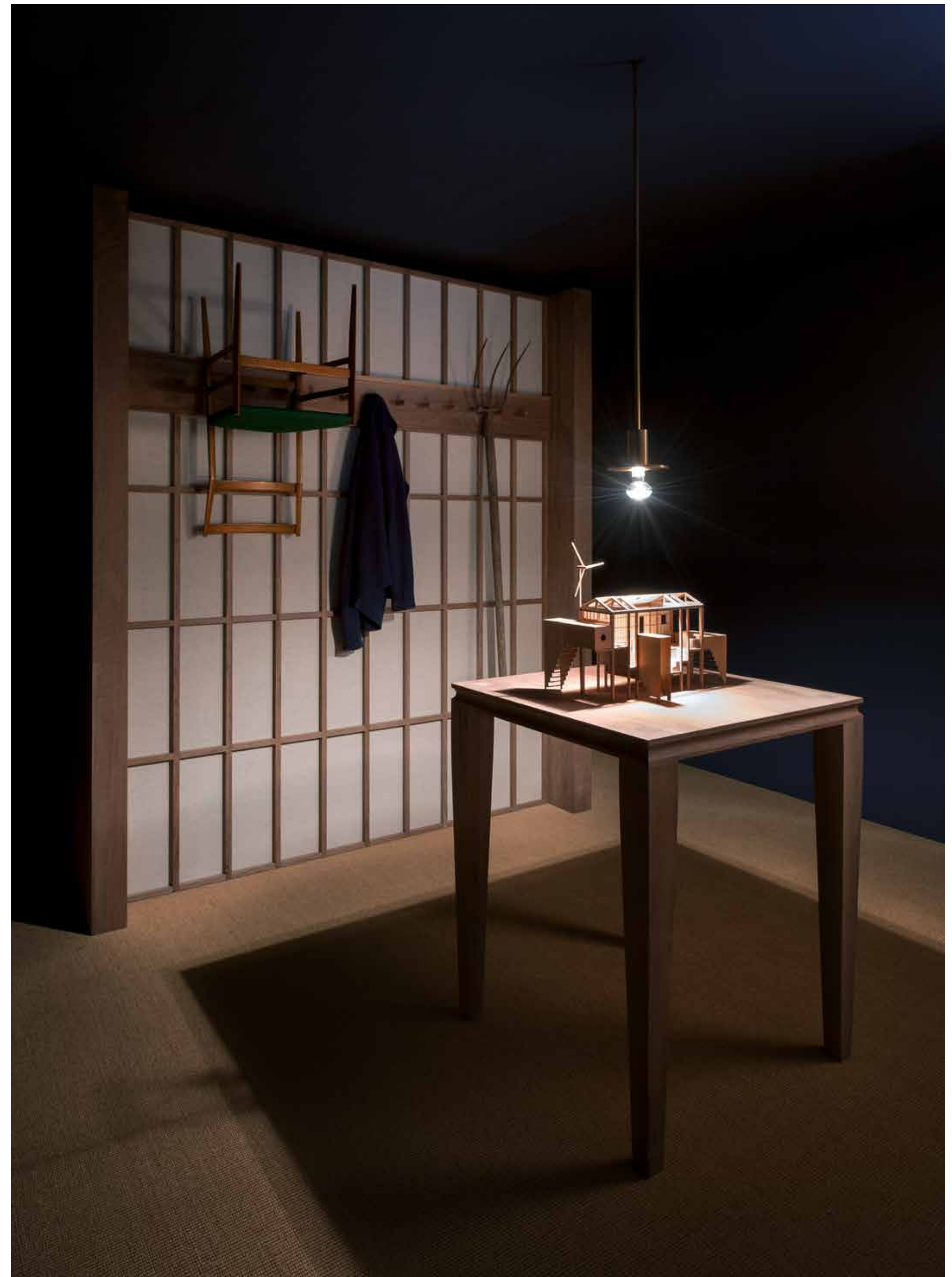



SOLISTA
PROD. DESINE
2018

A Servomuto (valet stand): no name was more suitable to describe an use. This involves a humble, clearly functional typology, made to serve more than to represent. In fact, it works to support clothes, to fold shirt and trousers, to prepare the evening before what will be worn the next morning, even the small accessories or jewels that complete the daily wardrobe. However, Solista is a valet stand that has detached itself from the choir. It realized that he had his own personality and that he could sing his solo. It becomes aware that it is not invisible and servile, but also beautiful and worthy of being appreciated when it is undressed. And then - like every good soloist - it knows how to return to the chorus of the domestic landscape and give its silent contribution.

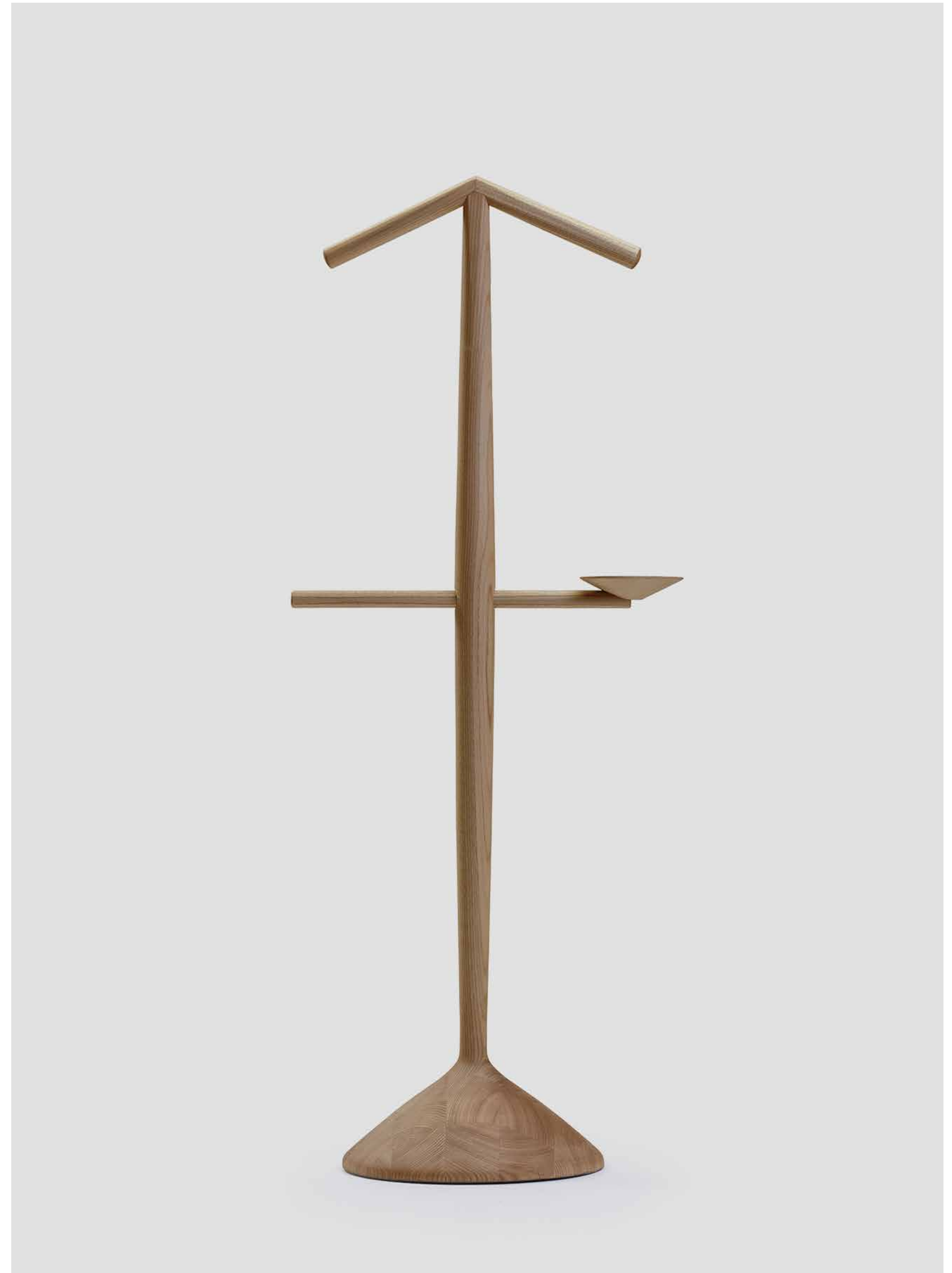
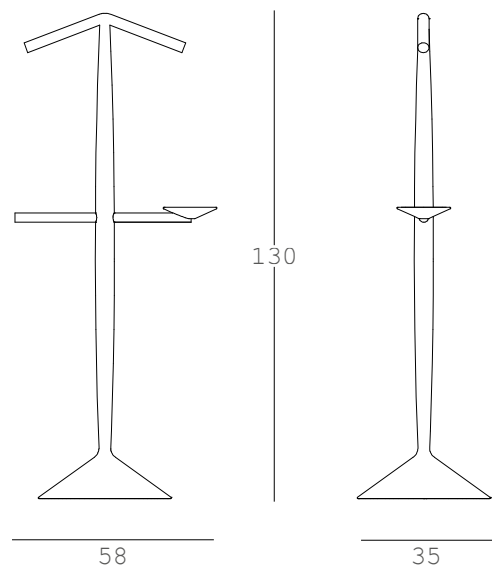



Solista is produced by the small brand Desine, it is made in chestnut solid wood, it can be finished also with a matt varnish.

Solista has been selected and exhibited at EDIT Napoli in 2019 and at the exhibition "Frontiere" part of the first edition of the Porto Design Biennale in 2019/2020.

BINOMIO
EDITION IT'S GREAT DESIGN
2019

Binomio is a hybrid piece, a two-sided object extending on three simple shelves placed at different heights from the floor. Its functions are many: it can be used as a desk or as a dressing room, but it can also be a table for dining alone, a bench to take off your shoes as you enter the house, a hanger, a bedside table, a bookshelf, an altar or a prie-dieu, as well as a support for any type of object. Binomio is made of solid beech wood and lacquered with bordeaux varnish. It is a domestic totem, imposing with its height but simple in its forms: ready to inspire and host many of the countless daily actions.

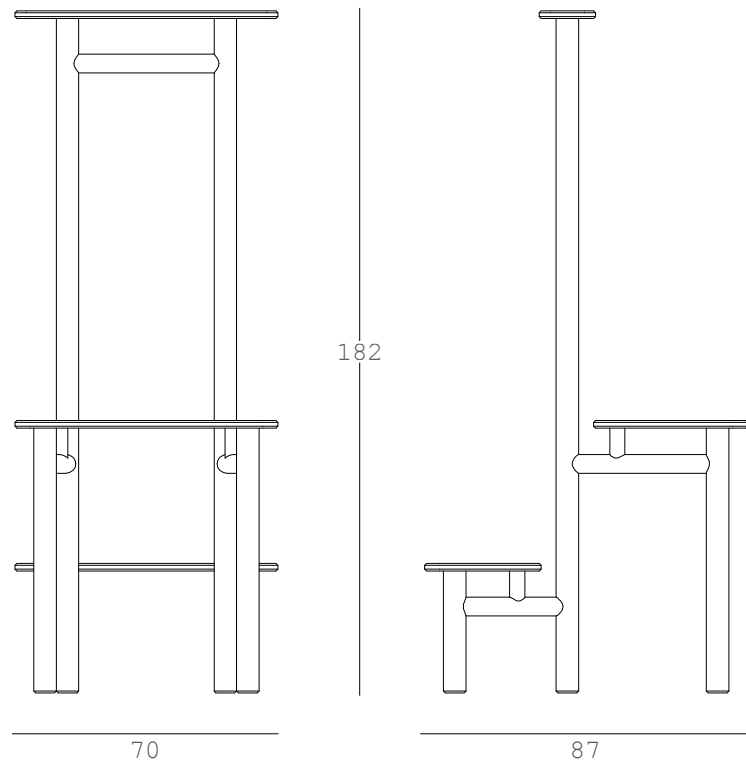



Binomio, presented for the first time at the Italian Institute of Culture in Paris, is handcrafted in Ragusa, Sicily, and it is edited in collaboration with "It's Great Design" in Paris. Binomio has been shortlisted as one of the 23 finalist projects among 862 international entries at the Pure Talents Design Contest 2020 at Imm Cologne. Binomio is part of the "Design and Decorative Arts" permanent collection of the "CNAP - Centre National des Arts Plastiques" in Paris

TRAMOGGIA
EDITION IT'S GREAT DESIGN
2020

Tramoggia, is the contemporary reinterpretation of the "cassapanca", it is realized in painted steel sheet and it is available in two versions.

The project proposes a new aesthetic, far from the beautiful solid wood cassapanca, more related to a vernacular culture, but at the same time functional and spacious. This new version is realized with a 1.5 mm thick steel sheet which makes the archetype of the chest more contemporary and light - thanks to its thin sections and a slight detachment from the ground. The design was developed around the pyramid shape of the chest.

Tramoggia is resistant and colored, it is available in single or double seat, and it can be indoor and outdoor.



TRAMOGGIA ARMCHAIR

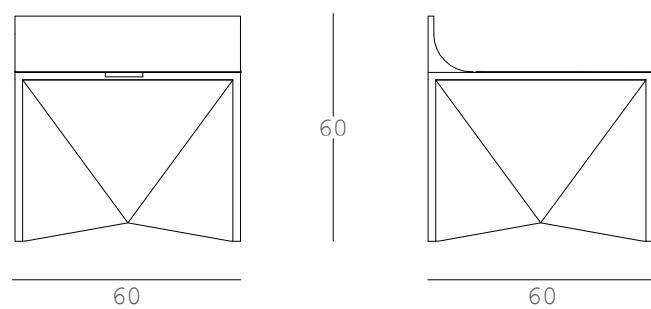

TRAMOGGIA BENCH

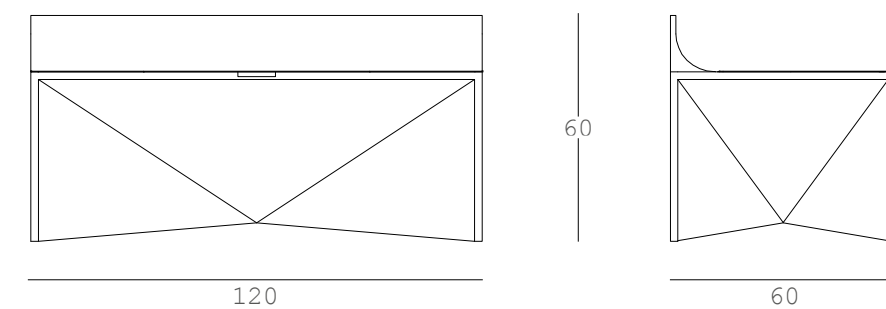



Tramoggia, is handcrafted in Varese, Italy, and it is edited in collaboration with "It's Great Design" in Paris.



CARRUBA
EDITION IT'S GREAT DESIGN
2021

A souvenir comes to mind. It comes to help: as a memory aid, a prop that sustains memories of places visited, a button that reactivates emotions or sensations. It is a personal object, which the culture of mass tourism has reduced to an impersonal standard toy mass-produced who knows where, obeying a vernacular devoid of nuance, the vehicle of a flat imagery, full of clichés. The tale of Sicily is particularly codified in this sense, and is suspended between folk and mafia, between the mournful blackness, the carnal brassieres and the coppole, the overflowing baroqueisms and a colourful dialect.

Carruba speaks of a south-eastern Sicily that everyone can see, but which escapes folkloric codification, and which for this reason appears perhaps reticent, grumpy, diffident - thus, indeed, profoundly and authentically Sicilian. A poor, rough fruit that is picked up from the ground but impregnates the air with a sweetly acrid perfume and is an important part of the local economy, the carob condenses the profoundly rural, agricultural nature of the place without rhetoric, indeed with naked directness.

Carruba captures this nature, immobilizes it and transfigures it: indeed, it fixes a moment, subtracting it from time, as befits a souvenir.

A living fruit changes its material: it cools down in an aluminium casting, it adopts the material skin of the most classic industrial souvenir, but it does so through a sand casting process that reconnects it to the earth. A process done in Sicily. Into the mould enters a rotten fruit; out of the mould comes an object that cannot rot, which is a doppelganger of the fruit, a fac simile, a twin. It is so above all in the tactile irregularity, in the roughness which, although cold, is yet another narrative layer, the final one: the epidermic apex of an authentic but not realistic tale.

Far from the swirls and brocades, like carts and octopuses squashed on the rocks, the genius loci emerges in Carruba's sibylline and broken-down dryness, in its hollowed-out, worn, deprived appearance.



MANICO
EDITION IT'S GREAT DESIGN
2021

Manico was born from a research project linked to the vernacular tradition and became an ergonomic product stripped of the superfluous. The new Manico armchair is a brightly colored indoor seat that interprets the simplicity of rural life.

Characterized by its lightness and transparency, Manico was made with the minimum use of material: equipped with an exposed ash wood structure and a fabric seat, it is completed by cushions that make it extremely accommodating.

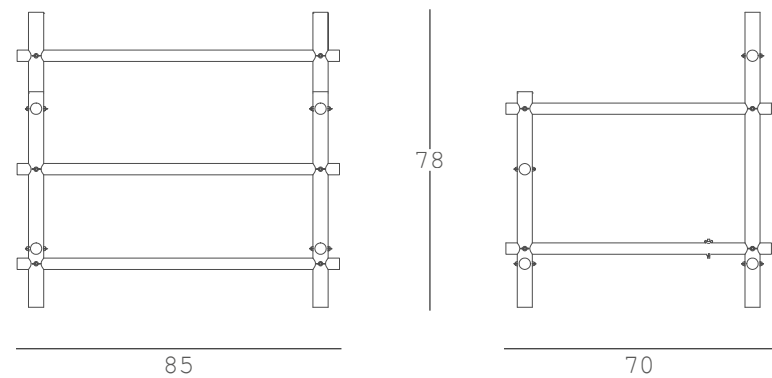



Manico, is handcrafted in Italy, and it is edited by "It's Great Design" in Paris. Structure in ash, seat in a mixed cotton/linen fabric available in 4 colors (blue, green, yellow, and cream), straps in natural leather, parts in stainless steel.



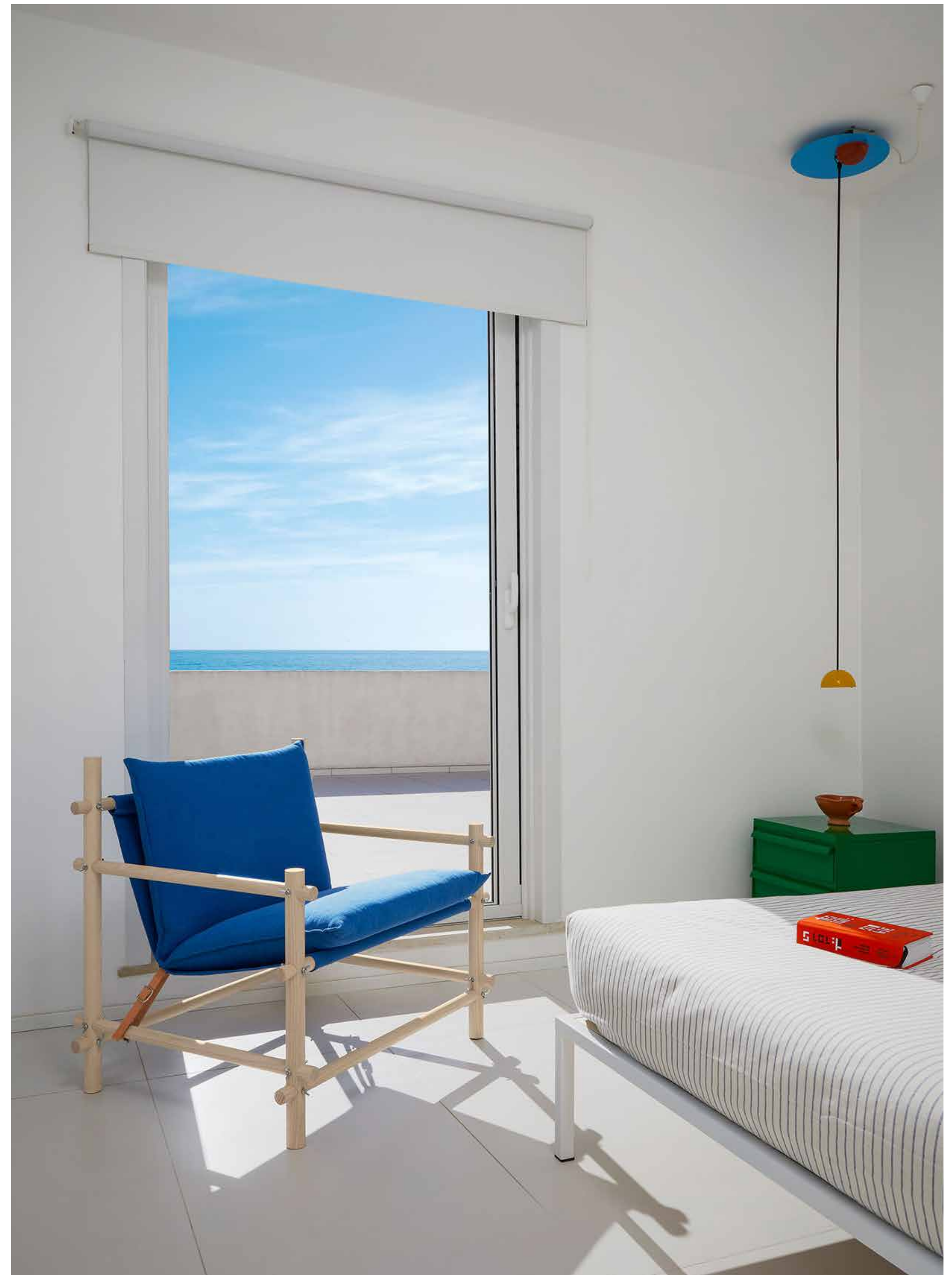

ELASETESALE
INSTALLATION
N'ORMA
CHIARAMONTE GULFI
2022

ElasetesalE is a site-specific installation, designed by Giuseppe Arezzi for N'orma, a small countryside hotel in Chiaramonte Gulfi.

A few years ago, the clients, Andreina Iebolle and Maurizio Di Gregorio, found they had 150 bottles without their normal green glass bases, made to have been used for a project that never got off the ground. These bottles which had been set aside still remained in their memories so, in the autumn of 2021, the designer Giuseppe Arezzi from Ragusa, was called in to propose his own personal interpretation of the unused containers.

This is how ElasetesalE was born: a palindrome, two-faced and almost circular, a 15.55-metre-long line consisting of 102 bottles, one inside the other, with the whole resting horizontally on slim iron trestles. The water flows inside the glass containers and then into a large funnel set up in the ground, which collects it and pushes it back into the circuit, without dispersion. The whole is operated by a simple red tap connected to a water system.

Giuseppe Arezzi: "The bottle I was shown is a perfect, anonymous object. It was enough to introduce it into the agricultural landscape and connect it to the few purely rural buildings, now a hotel and the residence of the owners.

ElasetesalE is of raw authenticity, fully immersed in its context, without any infatuation with the past or any other predictable tradition; recognizable to those who live in these places and also to those who discover them; contemporary in its essence. The installation is a celebration of water as a primary commodity to be preserved and not wasted. In its intrinsic contradiction, here it is the bottle that pours the liquid into the funnel and not viceversa, so as to return it to the earth from whose sources it springs.

ElasetesalE (it means: and thirst is increasing) is a message in itself: drought on our planet will bring thirst and overheating is not caused by the scarcity of water: it is the lack of knowledge and respect for the environment that we inhabit which is the problem."







FISCELLA
EDITION IT'S GREAT DESIGN
2022

Fiscella is a generously proportioned suspended object made from traditional wicker weaving on a painted brass rod frame. It hangs from the ceiling and can contain as well as be a point of light. An object that takes its name from the classic straw basket used in Sicily and the Mediterranean area to make ricotta cheese.

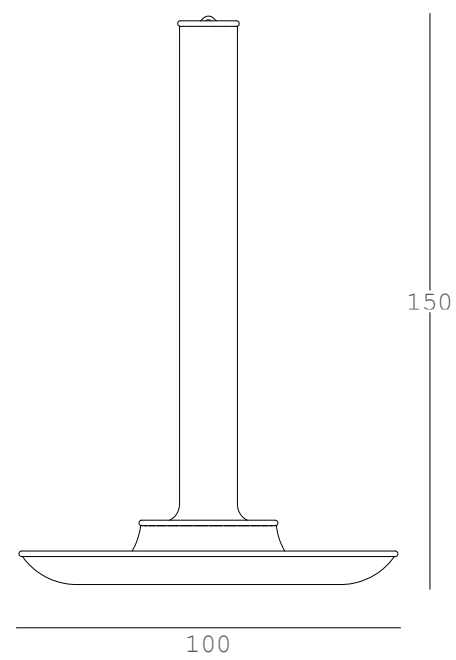



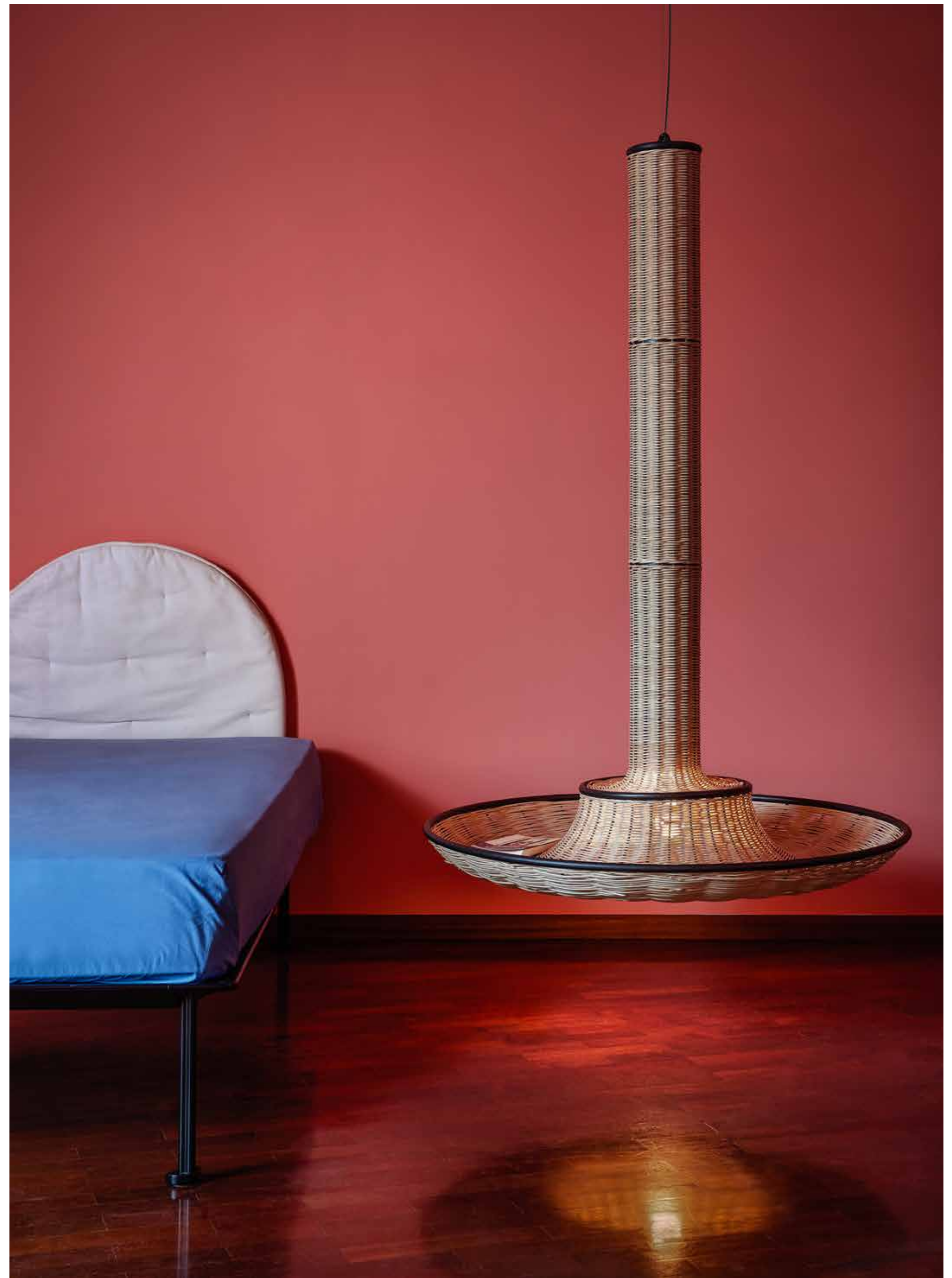
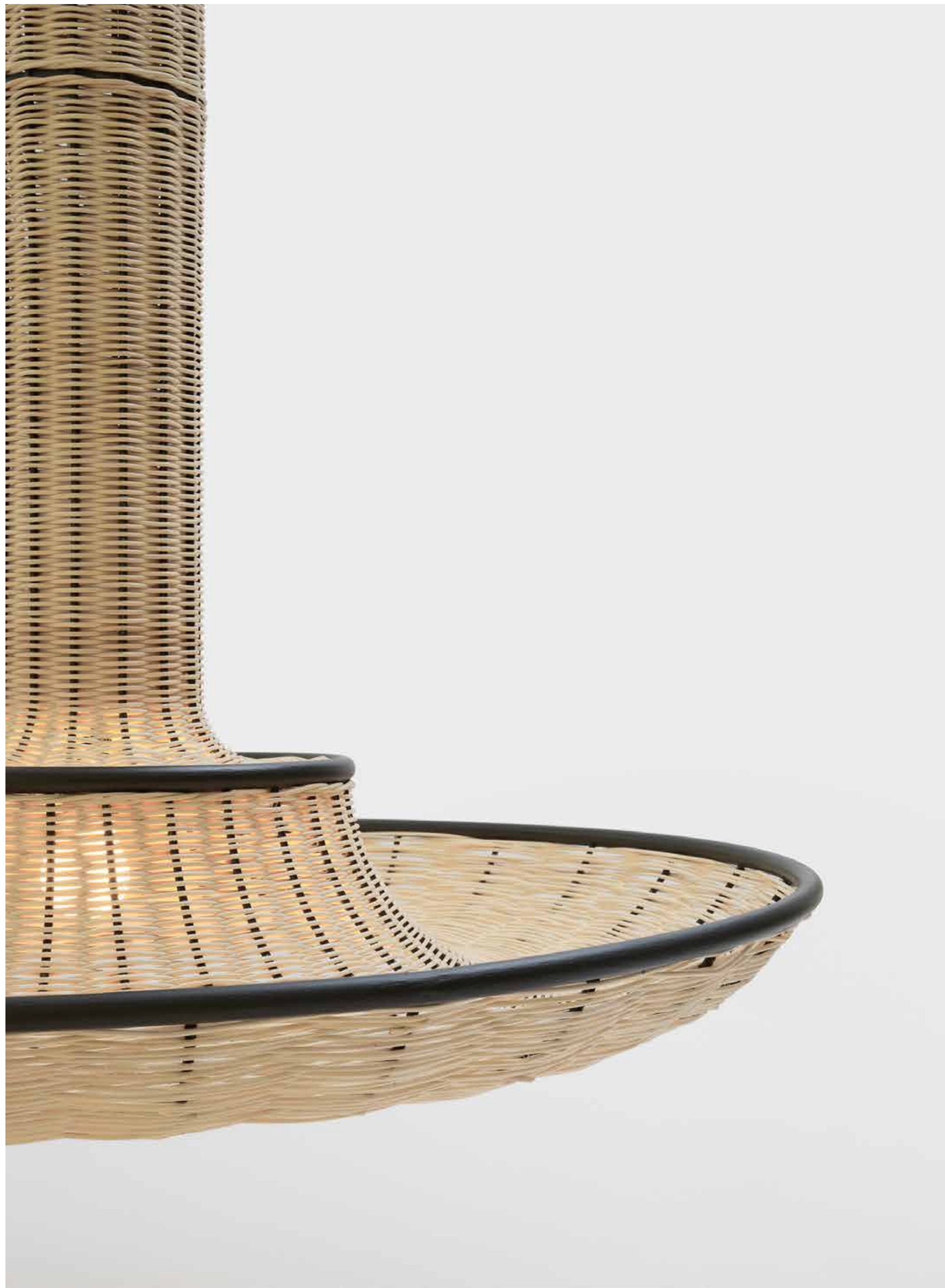

I PANIERI
EDITION IT'S GREAT DESIGN
2023

I Panieri are two new tableware objects made of woven wicker on a metal frame. Their shape is the result of the combination of two functions, the cylinder is to contain dry, elongated breads or breadsticks, the tray is useful to contain small breads. The two functions are punctuated by the rotation of the objects. 'I Panieri' project investigates new ways and rituals to serve bread at the table.



Dim: cm 15x30x7Ø
Dim: cm 15x20x7Ø



GIRO
EDITION IT'S GREAT DESIGN
2023

"Giro", is a contemporary carpet (Ø 2m) woven with a paper rope, which narrates the iconography of the vernacular wheel, known as the first object of mobility. It is a partly empty circular form, neutral in colour (grey), free of decoration, which dialogues with the space that surrounds it.

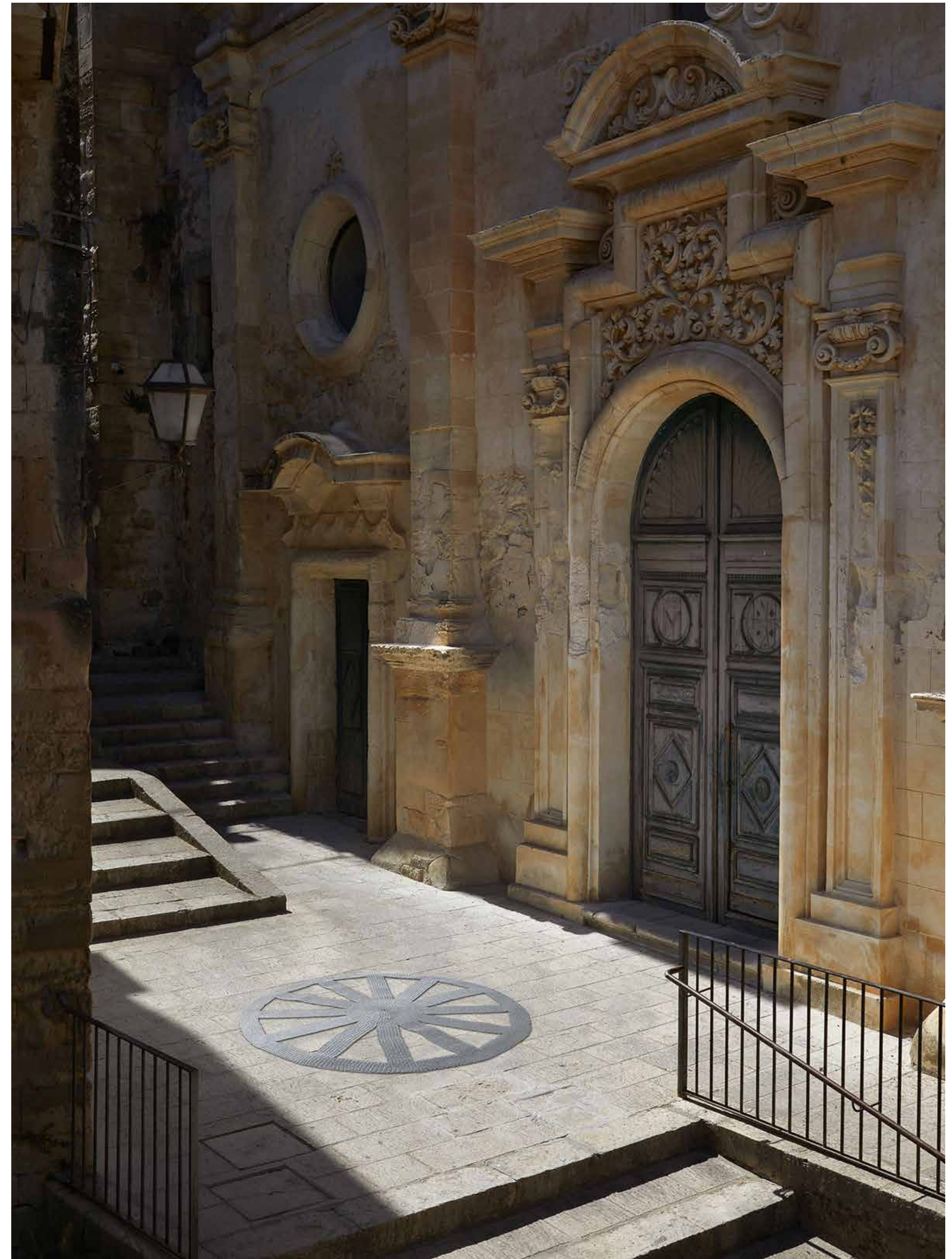
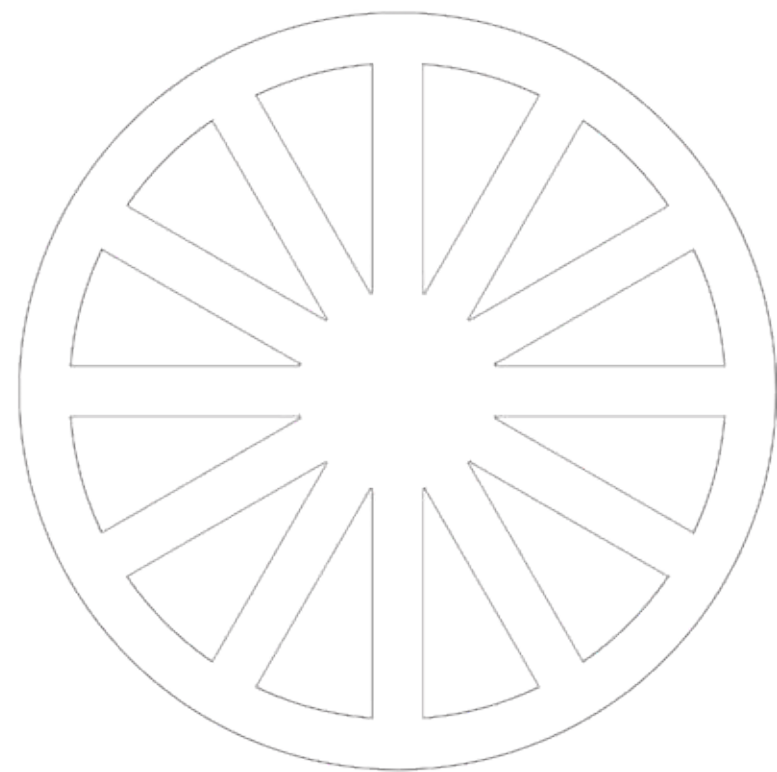

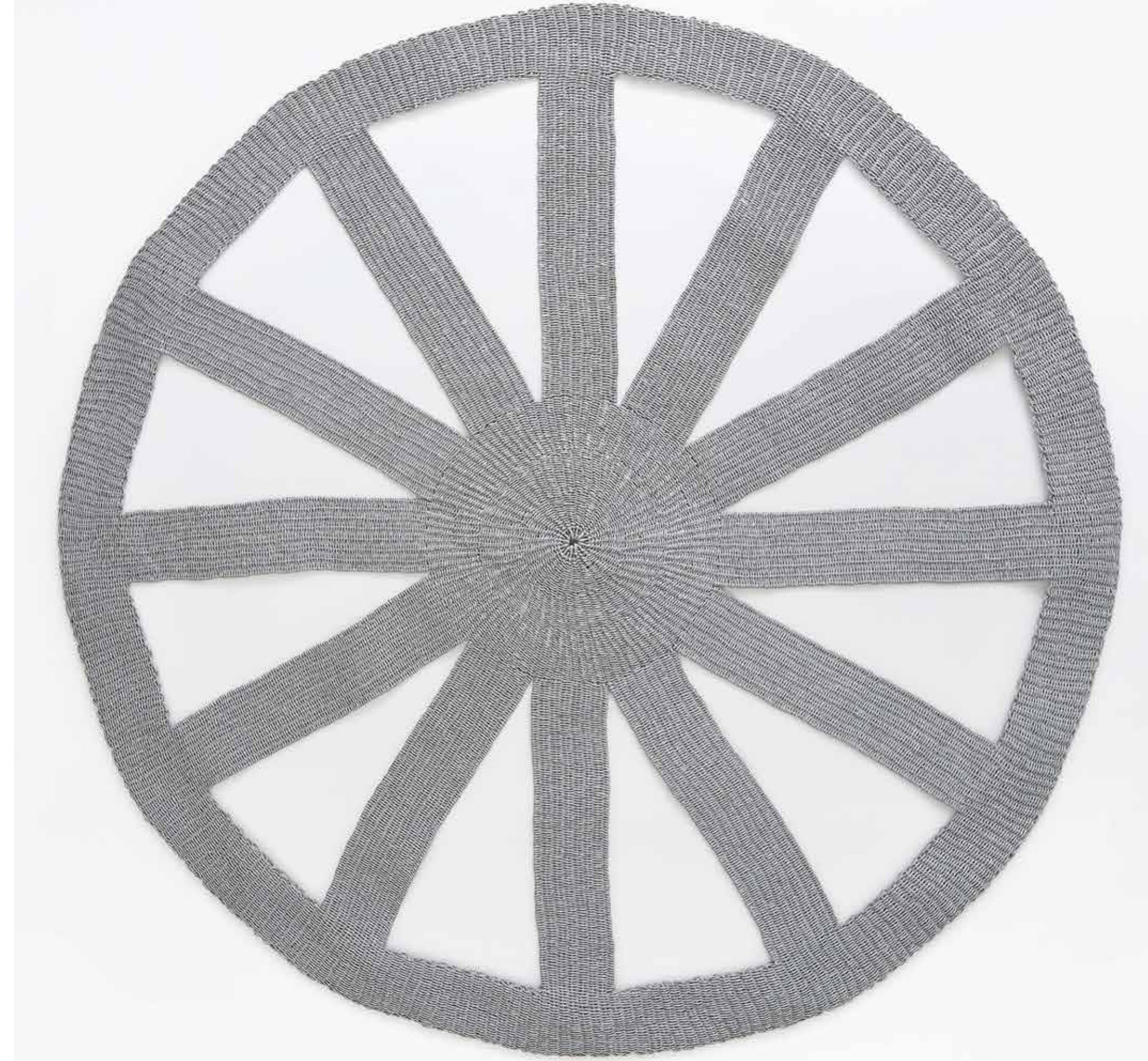

BRANDO
EDITION CAMPEGGI
2024

"Brando", is the new interpretation of the camp bed made of ash wood and fabric. Thanks to the skilful workmanship of the materials, the sophisticated accordion system gives the product extreme lightness and flexibility, ideal for adapting to the different needs of contemporary living.

Moreover, once the bed is closed, it turns into a comfortable upholstered bench, thanks to the addition of a soft reclining cushion.





VELARIO
EDITION LISPI
2024

The "Velario" four-poster bed takes its name from the ancient canopies used in Roman amphitheatres to shelter spectators from the sun.

The design features a linen curtain enriched with a geometric grid pattern in soft colours reminiscent of earth shades.

The structure reinterprets with rigorous and contemporary forms the traditional technique of wrought iron, already in the company's DNA, left exposed to enhance its materiality.

The bed, despite its imposing size, is on the contrary light and elegant, and brings to indoor environments the aesthetics and fascinations of life en plein air, defining a new way of conceiving the sleeping environment.

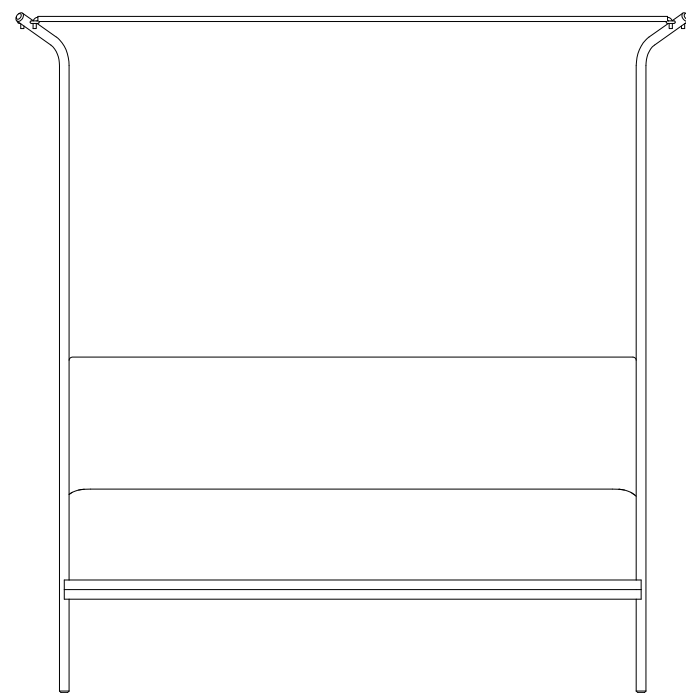

210

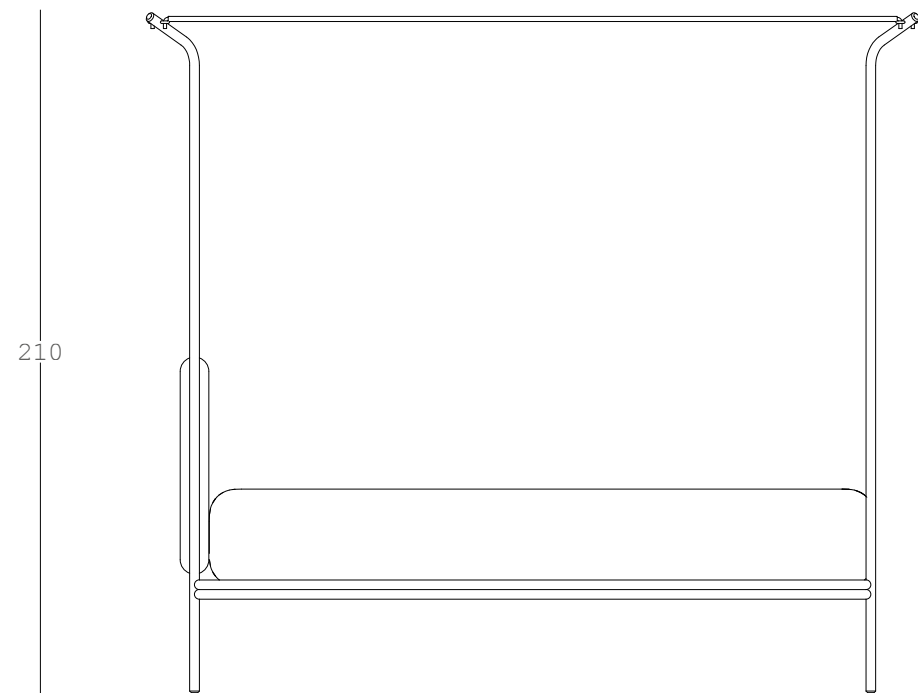

240





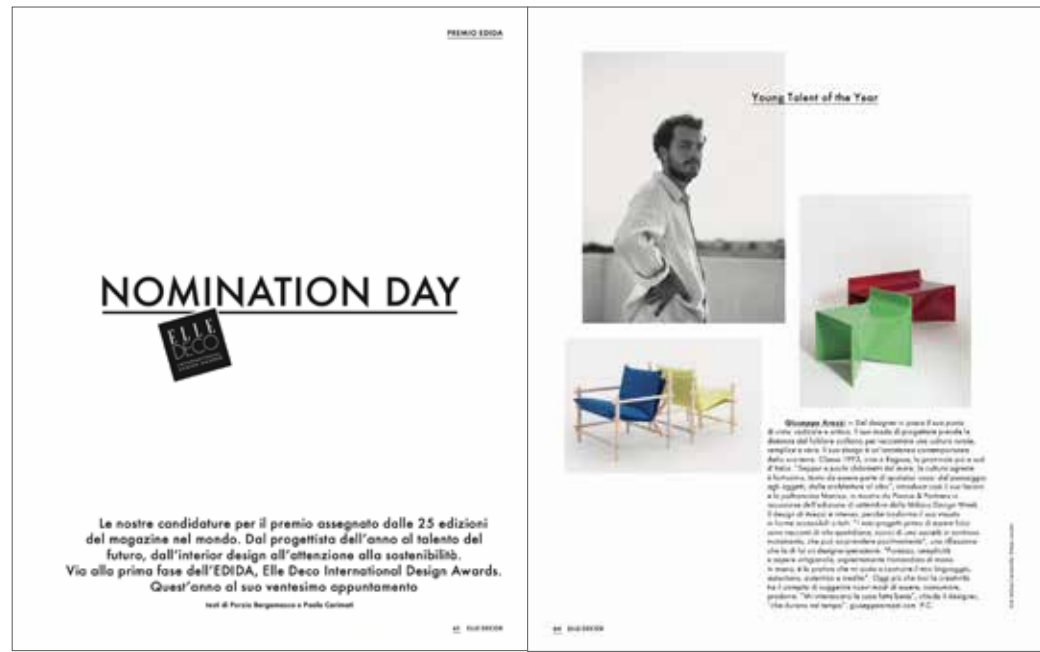

SELECTED EXHIBITIONS

2024
_Italy: A New Collective Landscape, HKDI Gallery, Hong-Kong
_Peripheral Design, Spazio Palmanova, Milan

2023
_Locus Amoenus, Ragusa Ibla
_Italy: A New Collective Landscape, ADI Design Museum, Milan
_ZOO Hub, Manifattura Tabacchi, Florence
_Voyage, Voyages, Arcade Design À La Campagne, Saint Colombe-en-Auxois
_Merging and Emerging, Movimento Club, Porta Venezia Design District, Milan

2022
_Si Sicilia, Design and Souvenirs, Ragusa Ibla
_Interieur Contemporain, La Bocca della Verità Gallery, Bruxelles
_3co Design, Ministero degli Affari Esteri, Italian Institute of Culture in Toronto

2021
_3co Design, Ministero degli Affari Esteri, Sea World Culture and Arts Center in Shenzhen
_3co Design, Ministero degli Affari Esteri, Doha Design District
_Bienvenue Design, Hotel La Lôuisiane, Paris Design Week
_Emerging Lines, Pianca & Partners, Milan Design Week
_Design Neo Rurale, Giuseppe Arezzi x It's Great Design, Ragusa Ibla
_3co Design, Ministero degli Affari Esteri, Italian Institute of Culture in Prague
_Present Continuous by Nèò, 5 Vie Milano

2020
_At Home 20.20 Projects For Contemporary Housing, MAXXI Museum, Rome
_Presentation 00 Design Brussels, Area 42, Bruxelles
_XXVI Compasso d'Oro - Mettere Radici, ADI Design Museum, Milan
_Pure Talents, Imm Cologne
_Best of Pure Talents, ZOW Fair
_Nèò, Courmayeur Design Weekend

2019
_Frontiere, New Expressions of Contemporary Design: Porto Design Biennale
_Lake Como Design Fair
_Edit Napoli
_Guiltless Plastic, Rossana Orlandi Gallery, Milan
_Giuseppe Arezzi, Dal Soggetto all'Oggetto: Italian Institute of Culture in Paris

2018
_Lake Como Design Fair
_100x100 Achille: Fondazione Achille Castiglioni, Milan
_Send Me The Future: Subalverno1 Gallery, Milan

2017
_Giuseppe Arezzi, Beata Solitudo: "Una Stanza Tutta Per Sé | Cantiere Galli Design", Rome

2016
_New Craft | Call Under 35: XXI Triennale, Milan

ACQUISITIONS IN MUSEUMS

2023
_Maurer Design Collection, Zollikon

2022
_Vitra Design Museum, Weil am Rhein

2021
_CNAP - Centre National Des Arts Plastiques, Paris

THANKS TO:

Cantiere Galli Design
Domitilla Dardi
Desine
Istituto Italiano di Cultura di Parigi
It's Great Design/Margherita Ratti
Angelo Flaccavento
N'orma
Campeggi
Lispi

PHOTO CREDITS:

Max Rommel
Francesco Conti
Fotogiunta
Melissa Carnemolla
Natale Leontini
Giovanni Emilio Galanello
Vincenzo Caccia
Francesca Ferrari

